

radicon 

with you at every turn

Roloid Gear Pump



Gear Pump  
CRP-1.00GB1210

# PRODUCTS IN THE RANGE

Serving an entire spectrum of mechanical drive applications from food, energy, mining and metal; to automotive, aerospace and marine propulsion, we are here to make a positive difference to the supply of drive solutions.

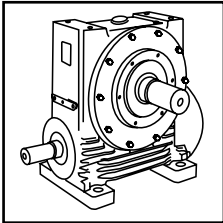

**Series A**  
Worm Gear units  
and geared motors  
in single & double  
reduction types

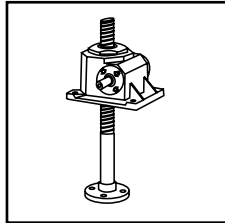

**Series BD**  
Screwjack worm  
gear unit

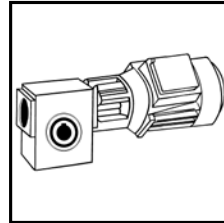

**Series BS**  
Worm gear unit

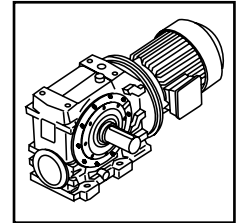

**Series C**  
Right angle drive  
helical worm geared  
motors & reducers

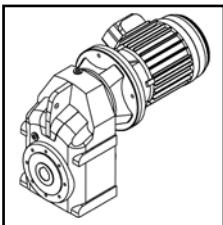

**Series F**  
Parallel angle helical  
bevel helical geared  
motors & reducers

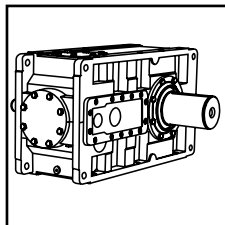

**Series G**  
Helical parallel shaft  
& bevel helical right  
angle drive gear  
units

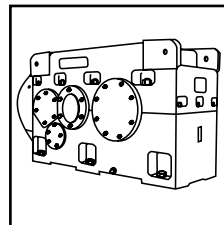

**Series H**  
Large helical parallel  
shaft & bevel helical  
right angle drive units

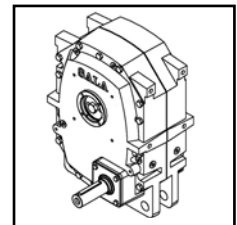

**Series J**  
Shaft mounted  
helical speed  
reducers

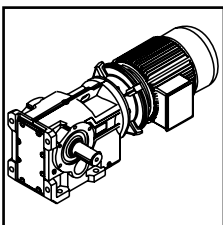

**Series K**  
Right angle helical  
bevel helical geared  
motors & reducers

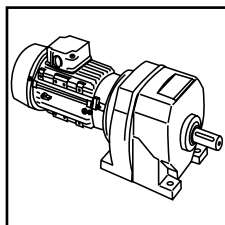

**Series M**  
In-line helical geared  
motors & reducers

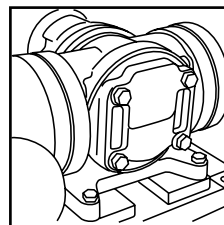

**Roloid Gear Pump**  
Lubrication and fluid  
transportation pump

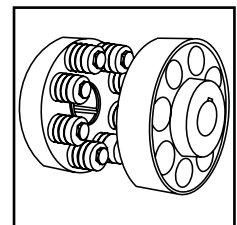

**Series X  
Cone Ring**  
Pin and bush  
elastomer coupling

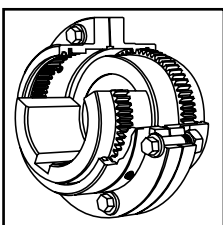

**Series X  
Gear**  
Torsionally rigid,  
high torque coupling

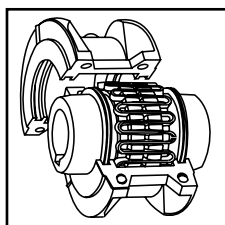

**Series X  
Grid**  
Double flexing steel  
grid coupling

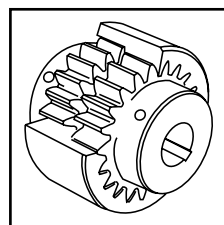

**Series X  
Nylicon**  
Gear coupling with  
nylon sleeve

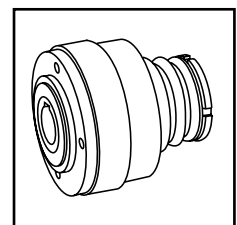

**Series X  
Torque Limiter**  
Overload protection  
device



We offer a wide range of repair services and many years experience of repairing demanding and highly critical transmissions in numerous industries.

We can create custom engineered transmission solutions of any size and configuration.

# ATEX Compliance Assured



Total compliance with the ATEX Directive safeguarding the use of industrial equipment in potentially explosive atmospheres is assured for users of our geared products.

Certification is available for standard gearboxes and geared motors with badging displaying the CE Mark and the Ex mark, name and location of the manufacturer, designation of series or type, serial number, year of manufacture, Ex symbol and equipment group/category.

ATEX directive 94/9/EC (also known as ATEX 95 or ATEX 100A) and the CE Marking Directive are enforced in all EC member states. Compliance is compulsory for designers, manufacturers or suppliers of electrical and non-electrical equipment for use in potentially explosive atmospheres created by the presence of flammable gases, vapours, mists or dusts.

Ex compliant standard gearboxes can be supplied against Groups 2 or 3 for surface industries in designated hazardous location Zones 1 and 2 for gases, vapours and mists; and in Zones 21 and 22 for dusts.

# ROLOID PUMP

---

## CONTENTS PAGE

---

Introduction _____	1
Product And Application Information _____	2
Roloid Pump Designations _____	3
Roloid Pump Selection _____	4
Dimensions Standard Pump Type H _____	5
Dimensions HST Pump Type T _____	6

---

# ROLOID PUMP

## INTRODUCTION

The Roloid Gear Pump is robust, compact and versatile. It is easy to install, extremely reliable, and requires little maintenance in service.

The pump design and product range have matured over many years and in combination with excellence, represents an economic and reliable solution to lubrication and fluid transportation problems.

**Roloid Gear Pumps** are suitable for pumping a wide variety of liquids which have some lubricating property.

Application engineers will gladly assist in selecting a pump that will give trouble free operation.

### **Roloid Gear Pumps Can Be Used For Lubrication Of:**

- Engines
- Compressors
- Gearboxes
- Rolling Mills
- Machine Tools
- Process Plant
- Pumping Sets
- Turbines

### **Roloid Gear Pumps Can Be Used For Pumping The Following Liquids:**

- Fuel Oils
- Open Circuit Servo
- Quenching
- Cutting and Cooling Fluids
- Oil/Water Emulsions
- Viscous Vegetable and Animal Fats
- Bitumen
- Wax
- Paint
- Lacquers
- Viscose

### **Features**

- Nine standard sizes with discharge variations for each to give exact flow required.
- Double helical rotors ensure low noise and non pulsating flow.
- Accurate manufacture of rotors and housings gives high efficiency, provides self priming and discharge pressures up to 20 bar.
- Robust journal roller bearings give long life and durability.
- Designed to rotate in either direction.
- Numerous attachments accessories and materials variants for specials.
- Foot or flange pump mountings.
- Bracket, baseplate or tank top housing motor mountings.

# ROLOID PUMP

## PRODUCT AND APPLICATION INFORMATION

### HST 'T' RANGE ROLOID PUMPS

#### **Background**

The 'HST' range Roloid Pump is an enhanced version of the standard 'H' range of pumps. The 'HST' shares many common components with the standard 'H' range and consequently the same wide range of features and benefits, but it is specifically designed and manufactured to meet the arduous requirements of lubrication systems for refrigeration compressors.

#### **Design and Manufacturing Specifications**

##### **Sealing**

Mechanical seals and 'O' rings are used due to high inlet pressures and to resist the corrosive nature of the refrigerant gasses.

##### **Bearings**

Special bearing arrangement - incorporating taper roller bearings to accommodate high thrust loads encountered due to high inlet pressures. All bearings are steel caged.

##### **Copper-based Alloys**

To achieve compatibility with the refrigerant gasses entrained in the lubrication oil, no copper or copper-based alloys are used in the construction of the pump.

##### **Testing**

All 'HST' pumps are hydrostatically tested at up to double the operating pressures to ensure reliable, leak-free operation.

##### **Selection Guidelines - HST Roloid Pumps**

In all cases selection of HST pumps should be referred to application engineers.

### API ROLOID PUMP ASSEMBLIES

#### **Background**

Designed to meet the exacting standards of API 676 specification, the API version of the Roloid Pump is a special adaption of the HST range of pumps and shares the same extensive features and benefits.

##### **Housings**

All housings are manufactured from high quality steel.

##### **Flanges**

Flange interfaces conform to ANSI B16.5 standards.

##### **Configuration**

The pump assembly is baseplate mounted, with motor, coupling and guard. Membrane type couplings are used to facilitate replacement of the coupling without disturbing the pump or motor.

##### **Sealing**

Mechanical seals to API 614.

##### **Bearings**

All bearings selected to give in excess of 25,000 hours L10 life.

##### **Quality Control & Documentation**

Our quality systems ensure we can meet the exacting requirements for quality control and documentation called for by API 676. Each order is manufactured to its own specific quality plan, which can be audited at any stage by the customer. Full mechanical and chemical test certification can be supplied where required.

##### **Selection Guidelines - API Roloid Pumps**

In all cases selection of API pumps should be referred to application engineers.

# ROLOID PUMP

## ROLOID PUMP DESIGNATIONS

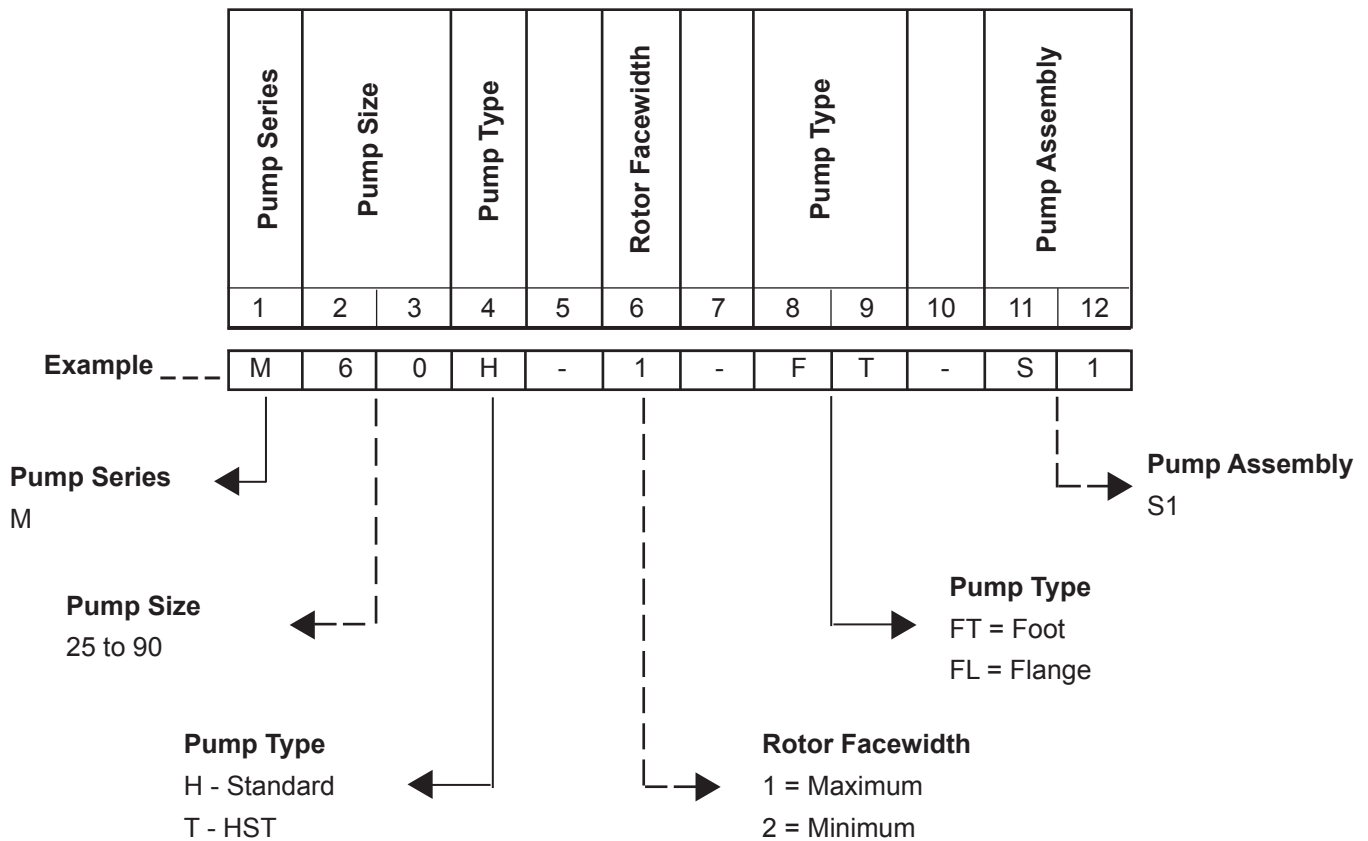

This designation series may be used only for standard pumps sizes 25 to 90

For non-standard and pump sizes 15 and 20 consult Application Engineering

To ensure correct selection, please contact our Application Engineers

Please provide the following information:

1. Discharge (Flow) Rate
2. Pump Speed
3. Details of Operating Environment (Ambient Temp, Application, Location etc..)
4. Operating Pressure
5. Inlet Pressure or Suction Lift
6. Operating Temp max/min
7. Pumped Fluid Type and Viscosity
8. Input Drive arrangement (Electric Motor, Gear Driven etc...)
9. Special Mounting Instructions, (Flanges, Brackets, Other etc...)

# ROLOID PUMP

## ROLOID PUMP SELECTION GUIDE

### NOMINAL FLOW - LITRES /MIN @ 100 CSt Viscosity and 3 BAR Differential Pressure

*Selections outside the above parameters to be referred to Application Engineering*

PUMP SIZE	ROTOR FACEWIDTH	RPM											
		100	200	300	400	500	600	725	850	960	1150	1450	2000
M90H	Min (25mm)				3.9	5.2	6.5	8.2	9.8	11.3	13.8	17.8	25
M90H	Max (38mm)				6.4	8.4	10.3	12.8	15.3	17.5	21	27	38
M70H	Min (33mm)				9.6	12.5	15.3	18.9	22	26	31	39	
M70H	Max (49.5mm)				15	19	24	29	34	39	47	60	
M60H	Min (38mm)				16	20	25	30	36	41	49	63	
M60H	Max (57mm)				24	31	38	46	54	62	74	95	
M50H	Min (46mm)				28	36	43	53	63	71	86	109	
M50H	Max (68mm)				43	55	66	81	95	108	130	164	
M40H	Min (57mm)		26	41	56	71	86	105	124	141	169	214	
M40H	Max (86mm)		41	64	86	109	132	160	189	214	257	325	
M30H	Min (76mm)		65	101	136	172	208	252	297	336	404		
M30H	Max (114mm)		100	153	207	260	314	380	447	506	608		
M25H	Min (90mm)	54	115	177	238	300	362	439	516	583	700		
M25H	Max (137mm)	82	174	267	359	452	544	659	775	877	1052		
20H	Min (114mm)	109	229	349	470	590	710	861					
20H	Max (171mm)	167	348	528	709	889	1070	1295					
15H	Min (152mm)	267	552	837	1122	1408	1693						
15H	Max (228mm)	407	834	1262	1690	2118	2546						

### POWER TO DRIVE - kW @ 100 CSt Viscosity and 3 BAR Differential Pressure

*Selections outside the above parameters to be referred to Application Engineering*

PUMP SIZE	ROTOR FACEWIDTH	RPM											
		100	200	300	400	500	600	725	850	960	1150	1450	2000
M90H	Min (25mm)				0.04	0.06	0.07	0.09	0.11	0.13	0.16	0.21	0.31
M90H	Max (38mm)				0.06	0.08	0.10	0.12	0.15	0.17	0.21	0.27	0.39
M70H	Min (33mm)				0.08	0.11	0.13	0.16	0.19	0.22	0.27	0.35	
M70H	Max (49.5mm)				0.12	0.16	0.20	0.25	0.29	0.34	0.42	0.54	
M60H	Min (38mm)				0.13	0.17	0.21	0.26	0.31	0.36	0.45	0.58	
M60H	Max (57mm)				0.20	0.26	0.32	0.40	0.48	0.55	0.67	0.88	
M50H	Min (46mm)				0.13	0.17	0.22	0.27	0.32	0.37	0.46	0.61	
M50H	Max (68mm)				0.36	0.47	0.59	0.73	0.88	1.0	1.3	1.6	
M40H	Min (57mm)		0.23	0.36	0.51	0.66	0.81	1.0	1.2	1.4	1.7	2.3	
M40H	Max (86mm)		0.34	0.55	0.77	1.0	1.2	1.5	1.9	2.1	2.6	3.5	
M30H	Min (76mm)		0.56	0.90	1.3	1.6	2.0	2.5	3.1	3.5	4.4		
M30H	Max (114mm)		0.86	1.4	1.9	2.5	3.1	3.9	4.8	5.5	6.8		
M25H	Min (90mm)	0.34	0.86	1.5	2.2	2.9	3.8	4.8	6.0	7.1	9.0		
M25H	Max (137mm)	0.50	1.2	2.0	2.9	3.8	4.8	6.0	7.4	8.6	10.8		
20H	Min (114mm)	0.67	1.7	2.9	4.3	5.8	7.3	9.5					
20H	Max (171mm)	0.98	2.3	3.9	5.6	7.4	9.3	11.9					
15H	Min (152mm)	1.5	3.9	6.8	10.0	13.5	17.2						
15H	Max (228mm)	2.3	5.5	9.2	13.3	17.7	22.3						



# ROLOID PUMP

## DIMENSIONS

### STANDARD PUMP TYPE - H

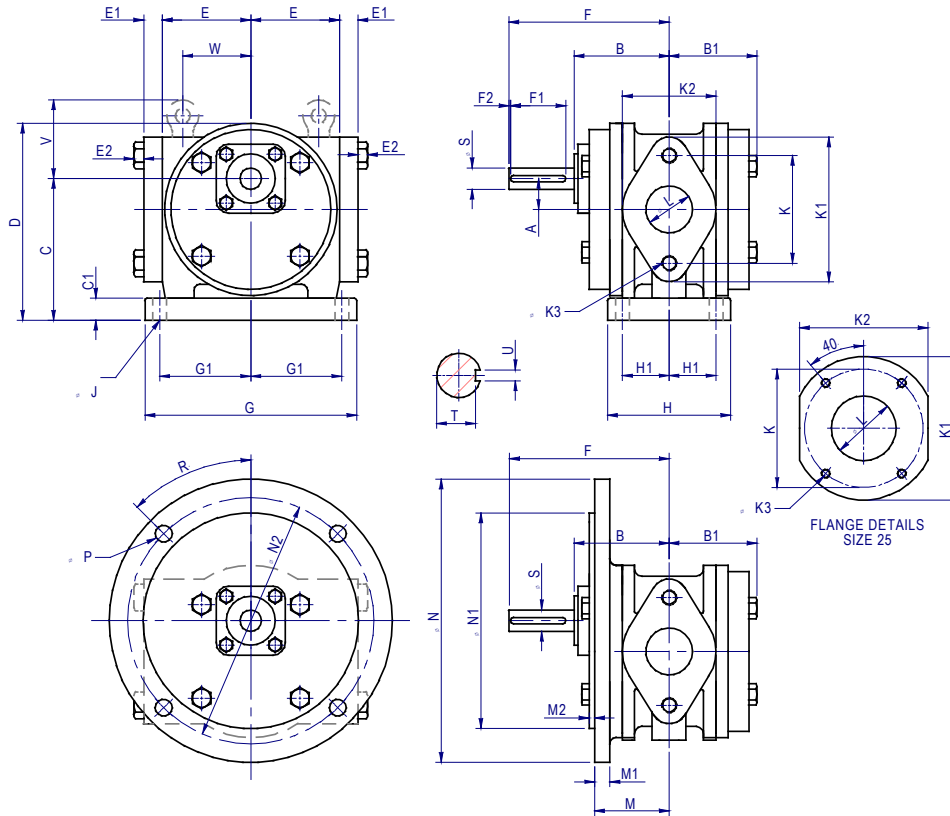

Dimensions in millimetres (unless specified otherwise)

PUMP SIZE	A	B	B1	C	C1	D	E	E1	E2	F	G	G1	H	H1	J	K	K1	K2	K3	L
M90H	14.1	62	55	79.4	14	113	49.2	10	8	101.6	127	54	70	25	4 x 9.5	57.2	79	48	2 x M10	25.4
M70H	18.1	66	60	95.6	17	137	61.0	13	8	114.3	152	65	89	33	4 x 11	71.1	97	56	2 x M10	31.4
M60H	21.2	71	66	106.4	19	150	66.0	13	10	127.0	160	67	89	32	4 x 11	81.3	112	64	2 x M12	38.1
M50H	25.4	87	82	120.7	20	169	76.2	19	10	139.7	178	74	104	37	4 x 12.7	88.9	121	76	2 x M12	44.5
M40H	31.8	102	93	146.3	23	203	91.4	19	12	165.1	218	94	127	48	4 x 14	111.1	149	97	2 x M16	50.8
M30H	42.3	127	121	190.5	29	264	118.1	25	12	203.2	272	118	170	67	4 x 17	152.4	198	127	2 x M16	76.2
M25H	50.8	145	140	228.6	36	318	141.0	25	12	228.6	330	142	203	79	4 x 21	177.8	216	150	4 x M16	88.9
20H	Consult Application Engineers																			
15H																				

PUMP SIZE									Shaft Details				Eyebolt		Net	Gross	Volume		
	M	M1	M2	N	N1	N2	P	R	S	T	U	F1	F2	V	W	kg	kg	cc	
M90H	43.7	10	5	168	4.8739"/ 4.8728"	146.1	4 x 10.3	45	7/16" (k5)	9.27	1/8"	3.2	19.1	-	-	6.4	11	11	
M70H	46.2	11	5	197	6.0000"/ 5.9988"	174.6	6 x 8.7	30	9/16" (m6)	11.6	3/16"	1.6	44.5	-	-	10	17	14	
M60H	55.6	16	3	229	6.9987"/ 6.9975"	203.2	8 x 13.5	45	5/8" (m6)	13.1	3/16"	1.6	44.5	-	-	14	21	17	
M50H	63.5	13	6	260	7.2487"/ 7.2475"	222.3	4 x 14.3	45	3/4" (m6)	16.4	3/16"	1.6	44.5	-	-	18	26	23	
M40H	77.0	16	6	292	8.7488"/ 8.7472"	254.0	4 x 17	45	7/8" (m6)	18.5	1/4"	3.2	57.2	-	-	32	40	36	
M30H	101.6	16	8	362	11.2493"/ 11.2481"	323.9	4 x 17	45	1-1/4" (m6)	28.0	5/16"	3.2	57.2	94	70	74	93	85	
M25H	117.5	16	8	483	14.9993"/ 14.9979"	431.8	4 x 21	0	1-3/8" (m6)	31.0	3/8"	3.2	63.5	102	96	111	150	140	
20H	Consult Application Engineers																		
15H																			

# ROLOID PUMP

## DIMENSIONS

### HST PUMP TYPE - T

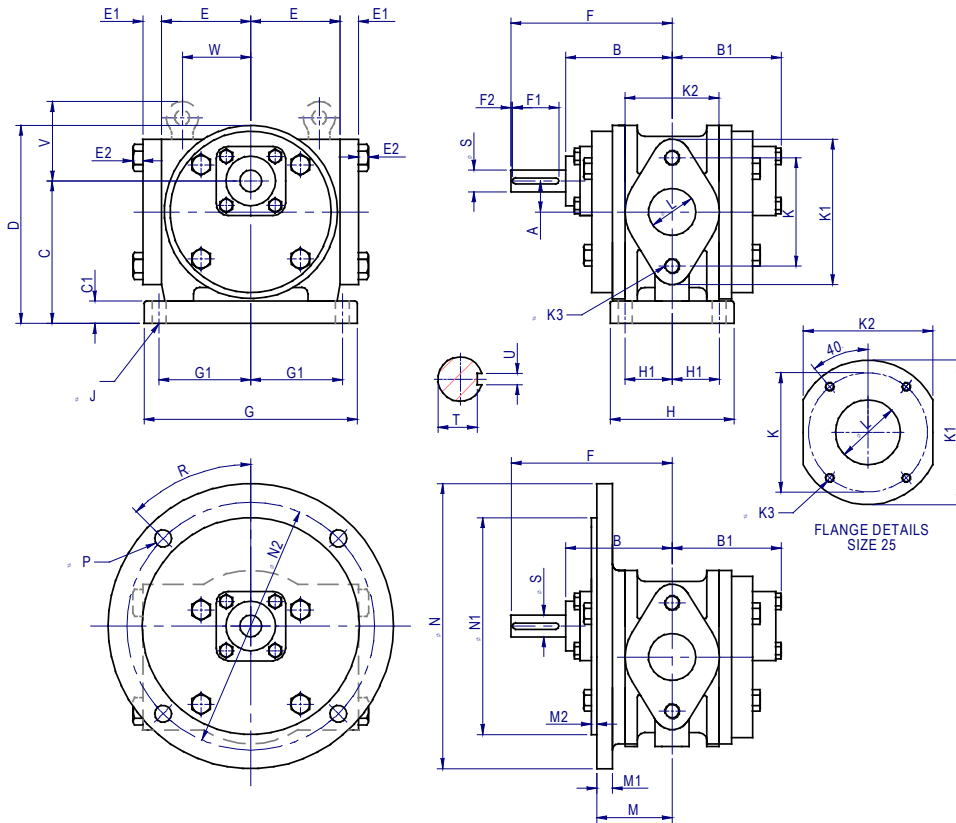

Dimensions in millimetres (unless specified otherwise)

PUMP SIZE	A	B	B1	C	C1	D	E	E1	E2	F	G	G1	H	H1	J	K	K1	K2	K3	L
M50H	25.4	99	102	120.7	20	169	76.2	19	10	139.7	178	74	104	37	4 x 12.7	88.9	121	76	2 x M12	44.5
M40H	31.8	109	114	146.3	23	203	91.4	19	12	165.1	218	94	127	48	4 x 14	111.1	149	97	2 x M16	50.8
M30H	42.3	147	147	190.5	29	264	118.1	25	12	203.2	272	118	170	67	4 x 17	152.4	198	127	2 x M16	76.2
M25H	Consult Application Engineers																			

PUMP SIZE									Shaft Details				Eyebolt		Net	Gross	Volume	
	M	M1	M2	N	N1	N2	P	R	S	T	U	F1	F2	V	W	kg	kg	cc
M50H	63.5	13	6	260	7.2487"/ 7.2475"	222.25	4 x 14.3	45	3/4" (m6)	16.4	3/16"	1.6	34.9	-	-	18	26	23
M40H	77.0	16	6	292	8.7488"/ 8.7472"	254.0	4 x 17	45	7/8" (m6)	18.5	1/4"	3.2	47.1	-	-	32	40	36
M30H	101.6	16	8	362	11.2493"/ 11.2481"	323.9	4 x 17	45	1-1/4" (m6)	28.0	5/16"	3.2	47.1	94	70	74	93	85
M25H	Consult Application Engineers																	

## IMPORTANT

### Product Safety Information

**General** - The following information is important in ensuring safety. It **must** be brought to the attention of personnel involved in the selection of the equipment, those responsible for the design of the machinery in which it is to be incorporated and those involved in its installation, use and maintenance.

The equipment will operate safely provided it is selected, installed, used and maintained properly. As with any power pumping equipment **proper precautions must** be taken as indicated in the following paragraphs, to ensure safety.

**Potential Hazards** - these are **not** necessarily listed in any order of severity as the degree of danger varies in individual circumstances. It is important therefore that the list is studied in its entirety:-

- 1) Fire/Explosion
  - (a) Oil mists and vapour maybe generated. It is therefore dangerous to use naked lights in the proximity of the pump openings, due to the risk of fire or explosion.
  - (b) In the event of fire or serious overheating (over 300 °C), certain materials (rubber, plastics, etc.) may decompose and produce fumes. Care should be taken to avoid exposure to the fumes, and the remains of burned or overheated plastic/rubber materials should be handled with rubber gloves.
- 2) Guards - Rotating shafts and couplings must be guarded to eliminate the possibility of physical contact or entanglement of clothing. It should be of rigid construction and firmly secured.
- 3) Noise - The machinery may produce noise levels which are damaging to the hearing with prolonged exposure. Ear defenders should be provided for personnel in these circumstances. Reference should be made to the Department of Employment Code of Practice for reducing exposure of employed persons to noise.
- 4) Lifting - Where provided (on larger units) only the lifting points or eyebolts must be used for lifting operations (see maintenance manual or general arrangement drawing for lifting point positions). Failure to use the lifting points provided may result in personal injury and/or damage to the product or surrounding equipment. Keep clear of raised equipment.
- 5) Lubricants and Lubrication
  - (a) Prolonged contact with lubricants can be detrimental to the skin. The manufacturer's instruction must be followed when handling lubricants.
  - (b) The lubrication status of the equipment must be checked before commissioning. Read and carry out all instructions on the lubricant plate and in the installation and maintenance literature. Heed all warning tags. Failure to do so could result in mechanical damage and in extreme cases risk of injury to personnel.
- 6) Electrical Equipment - Observe hazard warnings on electrical equipment and isolate power before working on the unit or associated equipment, in order to prevent the machinery being started.
- 7) Installation, Maintenance and Storage
  - (a) In the event that equipment is to be held in storage, for a period exceeding 6 months, prior to installation or commissioning, application engineering must be consulted regarding special preservation requirements. Unless otherwise agreed, equipment must be stored in a building protected from extremes of temperature and humidity to prevent deterioration.  
The rotating components (gears and shafts) must be turned a few revolutions once a month (to prevent bearings brinelling).
  - (b) External pump components may be supplied with preservative materials applied, in the form of a "waxed" tape overwrap or wax film preservative. Gloves should be worn when removing these materials. The former can be removed manually, the latter using a suitable solvent.  
  
Preservatives applied to the internal parts of the pump do not require removal prior to operation.
  - (c) Installation must be performed in accordance with the manufacturer's instructions and be undertaken by suitably qualified personnel.
  - (d) Before working on the pump or associated equipment, ensure that the load has been removed from the system to eliminate the possibility of any movement of the machinery and isolate power supply. Where necessary, provide mechanical means to ensure the machinery cannot move or rotate. Ensure removal of such devices after work is complete.
  - (e) Ensure the proper maintenance of units in operation. Use only the correct tools and approved spare parts for repair and maintenance. Consult the Maintenance Manual before dismantling or performing maintenance work.
- 8) Hot Surfaces and Lubricants
  - (a) During operation, pumps may become sufficiently hot to cause skin burns. Care must be taken to avoid accidental contact.
  - (b) After extended running the pump may reach temperatures sufficient to cause burns. Allow equipment to cool before servicing or performing adjustments.
- 9) Selection and Design
  - (a) The driving and pipework system must be correctly selected to ensure that the complete machinery installation will perform satisfactorily, avoiding system critical speeds, cavitation, blockages, vibration, etc.
  - (c) The equipment must not be operated in an environment or at speeds, powers, flowrates or suction lifts beyond those for which it was designed.
  - (d) As improvements in design are being made continually the contents of this catalogue are not to be regarded as binding in detail, and drawings and capacities are subject to alterations without notice.

The above guidance is based on the current state of knowledge and our best assessment of the potential hazards in the operation of the roloid pump.

Any further information or clarification required may be obtained by contacting an Application Engineer.

# CONTACT US

## ASIA

### **Elecon. Engineering Company Ltd.**

Anand Sojitra Road  
Vallabh Vidyanagar  
388120 Gujarat  
India

Tel: +91 2692 31170  
Fax: +91 2692 36559

## DENMARK

### **Benzler Transmission A/S**

Fuglebævej 3D  
DK-2770 Kastrup,  
Denmark

Tel: +45 36 34 03 00  
Fax: +45 36 77 02 42

## EUROPE

### **Benzler TBA BV**

Jachthavenweg 2  
NL-5928 NT Venlo

Netherlands & the rest of Europe

Tel: +31 77 324 59 00  
Fax: +31 77 324 59 01

Austria

Tel: +43 7 229 618 91  
Fax: +43 7 229 618 84

Germany

Tel: 0800 350 40 00  
Fax: 0800 350 40 01

France

Tel: +33 687 718 711  
Fax: +31 77 324 59 01

## FINLAND

### **Oy Benzler AB**

Vanha Talvitie 3C  
FI-00580 Helsingfors,  
Finland

Tel: +358 9 340 1716  
Fax: +358 10 296 2072

## SWEDEN & NORWAY

### **AB Benzlers**

Box 922 (Landskronavägen 1)  
251 09 Helsingborg  
Sweden

Tel: +46 42 18 68 00  
Fax: +46 42 21 88 03

## THAILAND

### **Radicon Transmission (Thailand) Ltd**

700/43 Moo 6  
Amata Nakorn Industrial Estate  
Tumbol Klongtumru  
Muang,  
Chonburi  
20000  
Thailand

Tel: +66 3845 9044  
Fax: +66 3821 3655

## UNITED KINGDOM

### **Radicon Transmission UK Ltd**

Unit J3  
Lowfields Business Park,  
Lowfields Way, Elland  
West Yorkshire, HX5 9DA

Tel: +44 (0) 1484 465 800  
Fax: +44 (0) 1484 465 801

## USA

### **Radicon USA Transmission Ltd**

1599 Lunt Avenue  
Elk Grove Village  
Chicago  
Illinois  
60007  
USA

Tel: +1 847 593 9910  
Fax: +1 847 593 9950

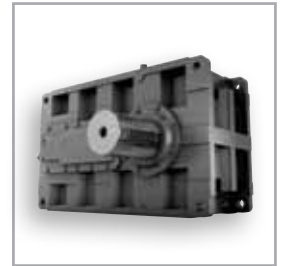
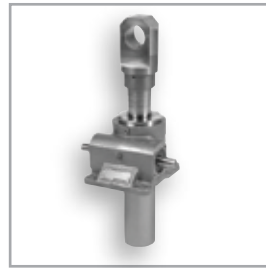

benzlers<sup>⚙️</sup>  
radicon<sup>⚙️</sup>

**Benzlers**

Denmark +45 36 34 03 00  
Finland +358 9 340 1716  
Germany +49 800-350 4000  
Sweden +46 42 186800  
The Netherlands +31 77 324 59 00  
[www.benzlers.com](http://www.benzlers.com)

**Radicon**

Thailand +66 3845 9044  
United Kingdom +44 (0) 1484 465 800  
USA +1 847 593 9910  
[www.radicon.com](http://www.radicon.com)